

Eigentum und Urheberrecht:
 Right of ownership and copyright:
IBAG Switzerland AG
 Oberfeldstrasse 20
 CH-8302 Kloten
 Tel. +41 43 888 33 33
 Fax +41 43 888 90 90

Paßmaß	Grenzabmaße
18 H5	+0.008 +0.000
100h6	+0.000 -0.022
100H6	+0.022 +0.000

KB = Klemmbereich
 CP = Clamping Possibility

Achtung: Diese Zeichnung zeigt eine Vielzahl an möglichen Options-Varianten.
 Bitte beachten Sie die technischen Datenblätter und Betriebsanleitung, bzw.
 die Auftragsbestätigung betreffend der Auslegung und Bestückung Ihrer Spindel.

This drawing shows the various possible options for this type of spindle.
 Please check with your technical data sheet, the instruction manual or your
 order confirmation regarding the options received and execution of your spindle.

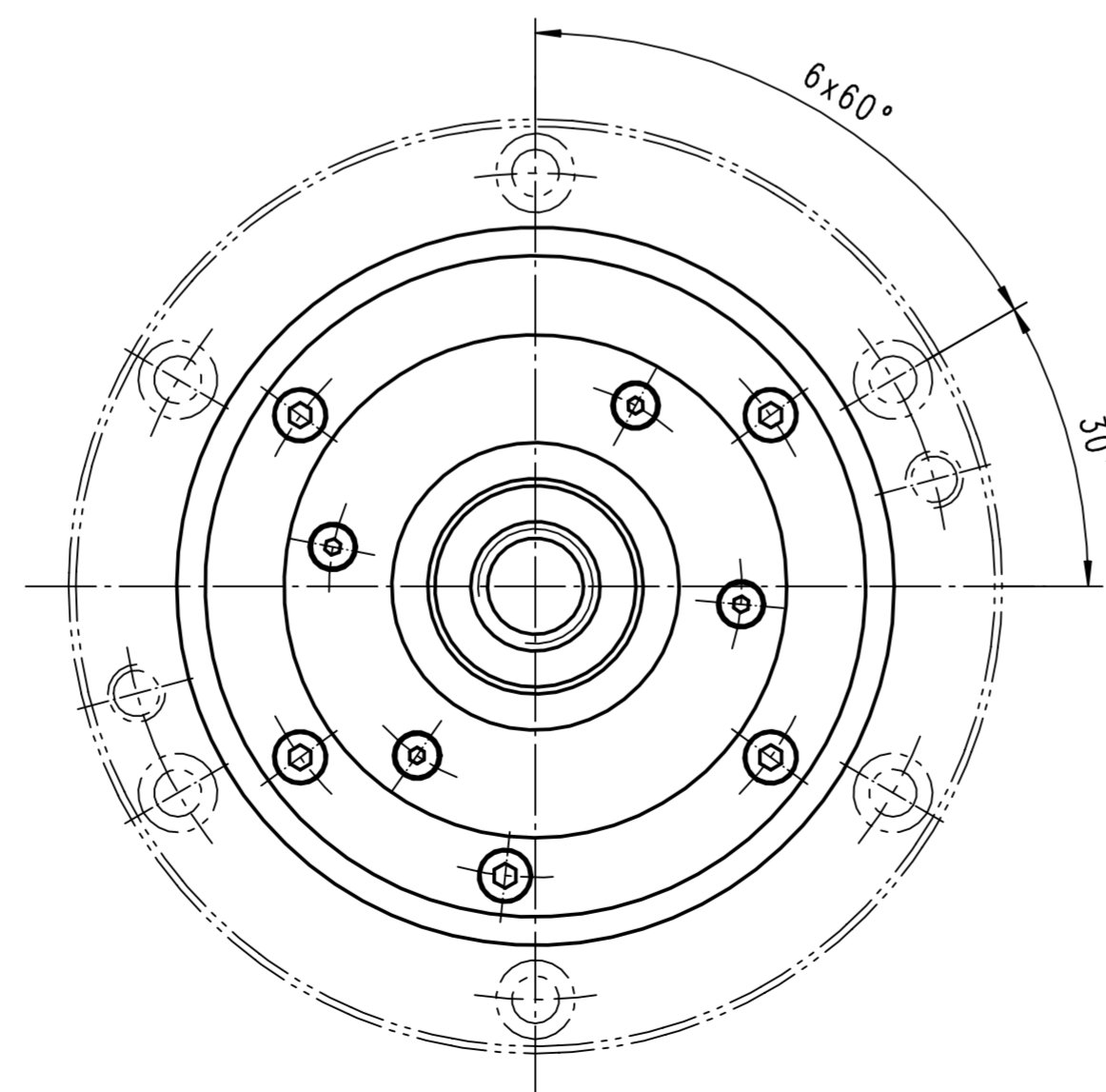
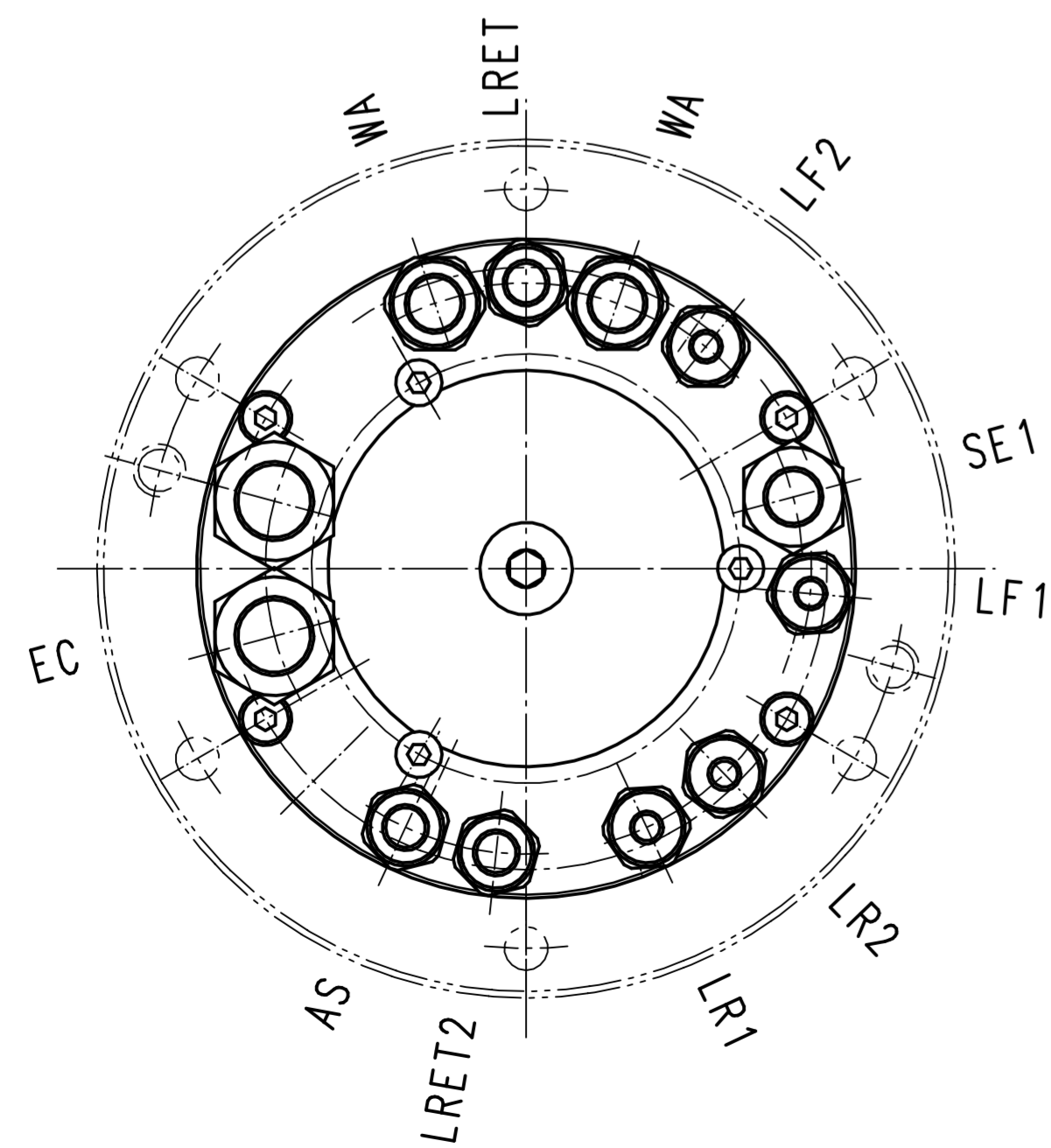

01	1	Motor Spindle/HF 100 D 45		
POS.	STK/PCT	BENENNUNG/TYPE	MATERIAL/NUMMER/NUMBER	
VERWENDUNG/TO BE USED FOR		MASSTAB/SCALE	EINHEIT/SCALE IN	FORMAT
HF 100 D 45		1:1	mm	DIN A1
		01.12.2014 11:51	BENENNUNG/TYPE	
E			Motor Spindle	
D			HF 100 D 45	
C			Motorspindel	
B			ZEICHNUNGSNUMMER/DRAWING NUMBER	
A	07.01.2014	fm	100D45-1A	
NEU/NEW	07.01.2014	fm	1/1	
GEPRÜFT/INSPECTED				
INDEX	DATUM/DATE	NAME	URSPRUNG/ORIGIN	
			IBAG Switzerland AG	

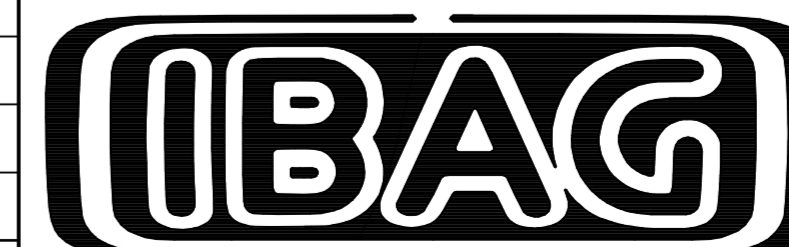

IBAG Switzerland AG